

# Analysis of the Stability of a Steel Truss Structure Footbridge based on Abaqus Software

Tianhao Ge \*

Swjtu-Leeds Joint School, Southwest Jiaotong University, Chengdu, Sichuan, 610000, China

\* Corresponding Author Email: Gth2022116132@my.swjtu.edu.cn

**Abstract.** Steel truss structure is widely used in bridge construction because of its high strength and light weight. At present, many researches have been carried out to analyse the stability of highway bridges by finite element analysis software, but the society has not deeply researched the stability of small-span footbridges. In this paper, we use abaqus software to build an indoor footbridge with a total length of 9m and a width of 2.5m, and the material chosen is Q235 steel, and the flexural and static analyses of the model are carried out by applying a load of 32,000N on it. The results indicate that the maximum stress of the steel truss structure occurs at the bottom reinforcement plate when the uniform load is applied to the bridge deck. The corresponding magnitude is 4.987 MPa. In addition, the maximum deformation of the structure occurs at the mid-span location, with a magnitude of 0.2026 m. The flexural modes show that the upper part of the truss chord bar and part of the web bar are susceptible to flexural instability. In addition, the linear buckling analysis gives a first order buckling load of 2.72772e6N, while the nonlinear buckling analysis results show that the buckling point load is 4.47124e6N, so the overall stability of the bridge meets the requirements. The main conclusions of this study can suggest optimisation for the design of indoor footbridge and promote the research of abaqus software in the stability of steel truss footbridge.

**Keywords:** Steel truss; pedestrian bridge; modal analysis; eigenvalue; buckling point.

## 1. Introduction

With the acceleration of urbanisation, the safety and stability of footbridges, as an important part of urban infrastructures, have received closer and closer attention. Steel truss structure has been widely used in the construction of footbridge because of its high strength and light weight. However, the stability problem of steel truss cannot be neglected when it is subjected to external loads. The 2018 collapse of the FIU pedestrian bridge in Miami, U.S., which destabilized the bridge's web bars under construction loads, resulting in a loss of the structure's compressive load carrying capacity. Therefore it is extremely important to carry out stability analysis to ensure that the footbridge can be used for a long period of time.

Abaqus, as a powerful finite element analysis software, has a unique role in the field of stability analysis. By using abaqus, the footbridge can be modelled finely, and the stress distribution and deformation of the truss structure can be analysed by applying different loads on its structure.

The stability study of steel truss footbridge is an important topic in the field of bridge engineering. In recent years, with the acceleration of urbanisation and the requirement of safety, aesthetics and economy of bridges, the relevant research has made significant progress. There have been related studies to determine the weak points of the structure by focusing on the structural stresses of assembled highway steel truss bridges under heavy trucks [1]. In addition, in order to evaluate the risk factors in the construction of steel truss bridges, Xudong Wang et al proposed a method based on the improved DEMATEL-ISM evaluation method, which is highly instructive for optimising the construction [2]. Piaolong et al. proposed the technique of eliminating the welded residual stresses in the upper chord bar of main trusses of steel truss bridges, which further extends the research in this field of stability of steel truss bridges [3]. Irpan Hidayat et al. obtained a mathematical model between deflection and bridge rotation, which provides a basis for bridge stability analysis [4]. Despite significant developments in the study of large-span road bridges, there is still a lack of research on the stability of small-span footbridges.

Building on the above studies, in order to meet the demand of pedestrians during the peak travelling period in the city, this study proposes to build a footbridge, the main bridge of which adopts a single-span simply-supported steel truss structure, and take this as the background to study the stability of the steel truss structure footbridge. The purpose of this study is to provide a reasonable opinion on the construction of steel truss footbridges by comparing the results of the study with the specification. And also to promote the development of abaqus software in the field of steel truss structure analysis.

## 2. Structure Selection

### 2.1. Basic parameter

In this paper, the pedestrian steel truss with a span of about 6.6m and a total length of 9m is erected indoors, with the main function of aisle. The total width of the bridge deck is 2.5m, the height of the left and right steel trusses is 2000mm, and the spacing of the webs is 1650mm. The specific arrangement is shown in Fig. 1.

The flyover using shell unit and beam unit modelling, the bridge deck and the bottom of the longitudinal and transverse reinforcement plate using shell, set the thickness of 10mm, the bridge above the protection network using beams, beam cross-section for the rectangular tube, size 100 \* 100mm, wall thickness of 3mm.

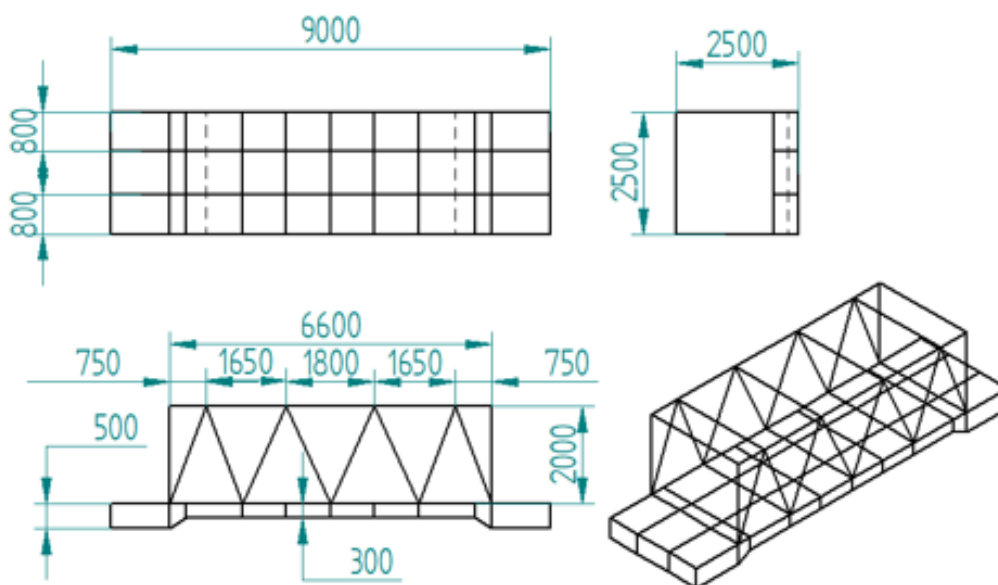

Fig 1. Flyover model and structural layout.

### 2.2. Material properties

Structural steel grade Q235,  $E=210,000$  MPa, poisson's ratio =0.3, yield strength= 235Mpa.tensile strength is 370Mpa.Specific data are shown in Table1.

Table 1. Material properties.

material	Modulus ofelasticity	Poisson's ratio	Yield strength	Tensile strength	Density/ton per $mm^3$
Q235	210000Mpa	0.3	235Mpa	370Mpa	7.85e-9

## 3. Modelling

### 3.1. Model Inspiration

The model draws on a finite element model created by a design company to perform finite element simulation of the main bridge steel trusses [5]. The reference model is shown in Figure 2.

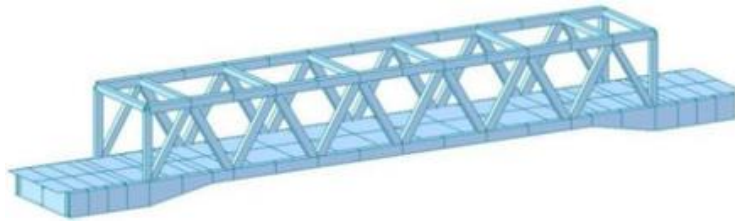

Fig 2. Reference model.

### 3.2. Boundary condition

To facilitate the imposition of boundary conditions, reference points are established at the centre of the support areas at both ends of the bridge, which are coupled to the bottom plate edges. The operation process is shown in Fig. 3.

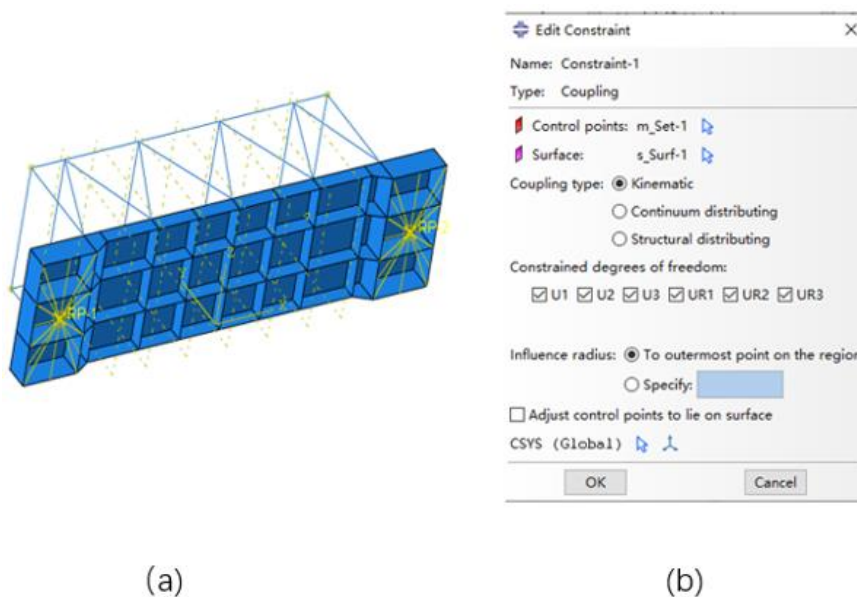

Fig 3. (a) Reference point coupling; (b) Edit constraints.

The reference point is fixed as a boundary condition. Because the bridge is a pedestrian walk, the load can only be estimated, according to the bridge uniformly distributed 40 people, each person weighs 80Kg, then the total load is:  $40 * 80 * 10 = 32000N$ , the acceleration of gravity is taken as 10. 32000N load evenly distributed on the bridge.

### 3.3. Grid

The shell is made of quadrilateral S4R shell unit and the beam is made of B31 beam unit. Unit size 60mm.

The result of grid division is shown in Fig. 4.

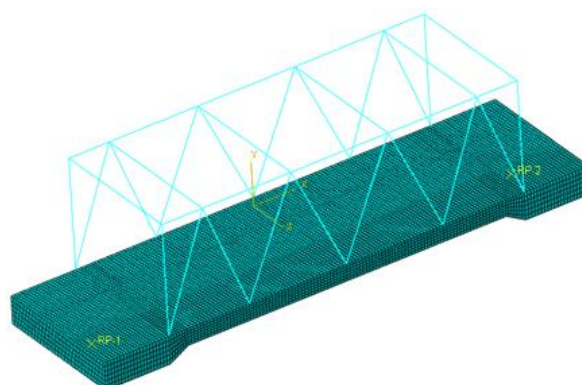

Fig 4. Result of grid division.

## 4. Analysis of calculation results

### 4.1. Static analysis

#### 4.1.1. Stress distribution

Through finite element analysis, the stress cloud of the main truss under pedestrian load is obtained. Fig. 5(a) and Fig.5 (b) show the stress distribution on the bridge deck and the bridge base respectively. By comparing these two stress distribution diagrams it can be seen that the maximum effective stress of the truss is 4.987Mpa, which appears at the reinforcement plate at the bottom of the bridge and is much smaller than the yield strength of 235Mpa, so the static strength of the bridge deck meets the requirements. Therefore, the static strength of the bridge deck meets the requirement. The effective stresses in other areas are basically concentrated in the range of 1.047-2.909Mpa. All have not reached the yield strength, and uniformly distributed in the bridge deck and bars, so the ability of the bridge to withstand the stress meets the actual needs, and is not easy to fatigue damage or crack expansion.

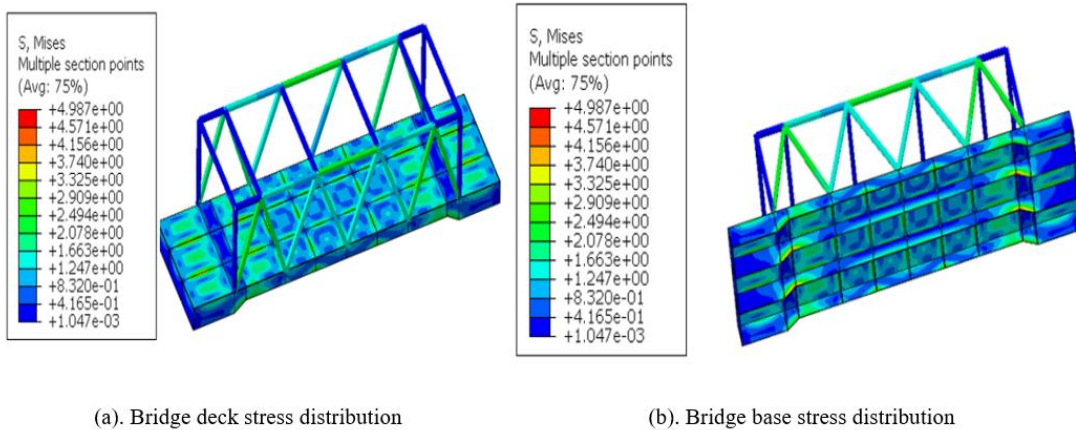

**Fig 5.** (a) Bridge deck stress distribution; (b). Bridge base stress distribution.

#### 4.1.2. Map of deformed clouds

The deformation cloud can be visualized by showing the deformation distribution of the structure under pedestrian loads. Areas of lower stiffness usually show larger deformations, suggesting the need for design enhancement or optimization of the structural form. Therefore, by analyzing the deformation maps, it is possible to understand where the structural stiffness needs to be improved. The deformation distribution is shown in Fig. 6.

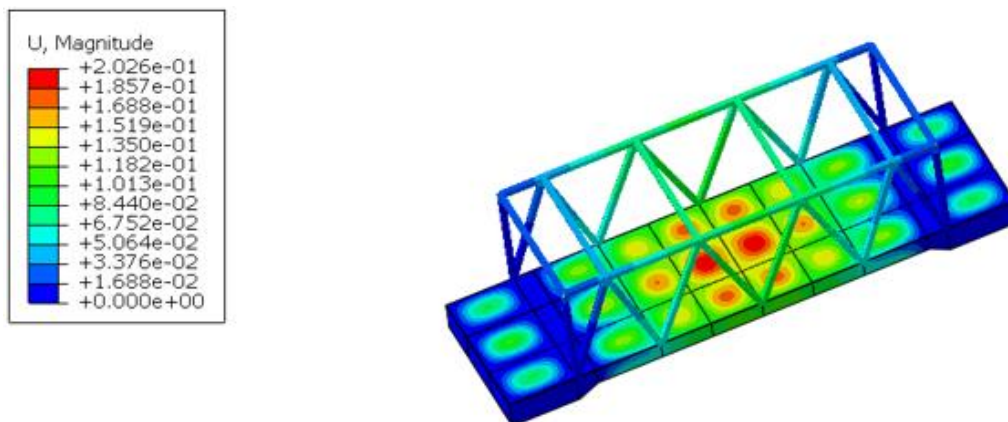

**Fig 6.** Map of deformation distribution.

Through the deformation cloud diagram, it can be seen that the maximum deformation of the bridge deck is 0.2026mm, concentrated in the mid-span region.

Under long-term loading, the deformation in this mid-span region may gradually accumulate, leading to a reduction in local stiffness, which in turn affects the stability of the overall structure. In

addition, the concentration of the deformation region will lead to the local material repeatedly subjected to large stress amplitude, which is easy to produce fatigue cracks. Once formed, fatigue cracks will gradually expand, which may eventually lead to local fracture or overall failure, shortening the service life of the bridge. According to China's Code for the Design of Steel Joists (GB50017-2017), the deflection of a steel joist should be no greater than  $\text{span}/1000$ ,  $0.2026 < \frac{9000}{1000} = 9\text{mm}$ , structural rigidity meets requirements [6].

**4.2. Modal analysis**

Observation of the first and second order buckling modes shows that the upper chord of the truss is prone to buckling instability, while the third and fourth order buckling modes indicate that there is also a risk of instability at the upper web position of the truss (Table 2 and Fig.7).

**Table 2.** First 4 orders of intrinsic frequency.

mode	value	frequent
mode 1	4080.2	10.166
mode 2	7768.3	24.377
mode 3	23460	39.012
mode 4	60084	45.57

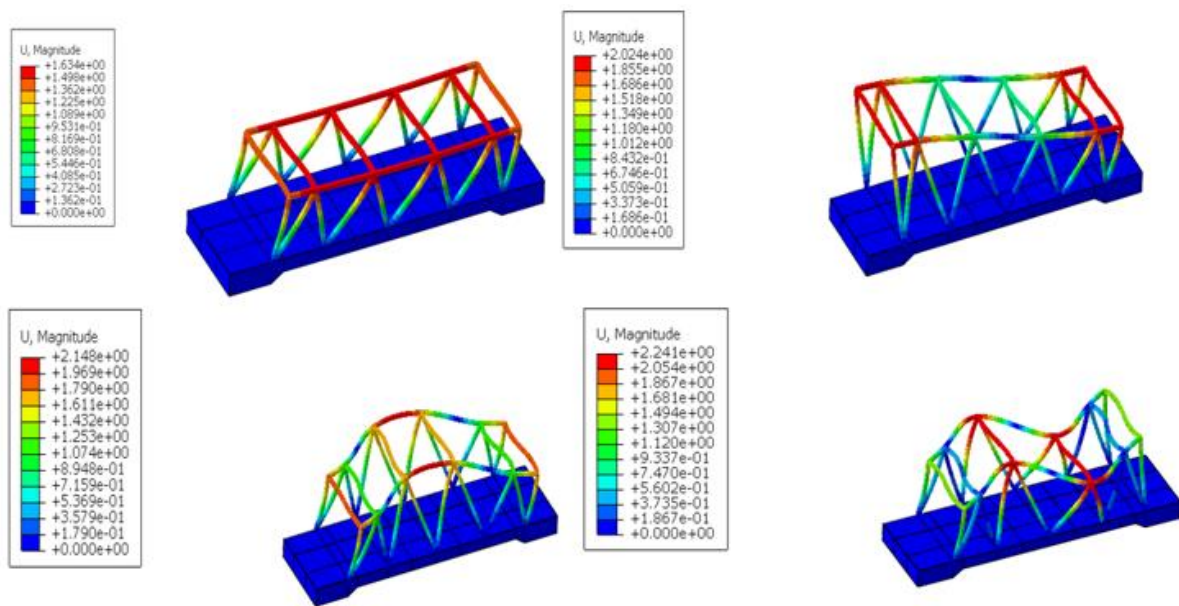

**Fig 7.** Vibration pattern.

**4.3. Linear buckling analysis**

The boundary conditions are unchanged and a uniformly distributed load of 1N is applied to the bridge deck to extract the first 8 orders of eigenvalues, which are shown in Table 3 below:

**Table 3.** Eigenvalues.

index	Eigenvalue
1	4.47E+06
2	4.47E+06
3	4.50E+06
4	4.50E+06
5	5.41E+06
6	5.41E+06
7	5.42E+06
8	5.42E+06

The eigenvalue multiplied by 1 is the buckling load because of the 1N load applied. The linear buckling analysis here can only be used as a preliminary condition for the stability analysis, and the eigenvalues obtained are only taken as the smallest first order. The first order buckling load is 4.47124e6N [7, 8].

The first six orders of flexural vibration patterns are shown in Fig.8:

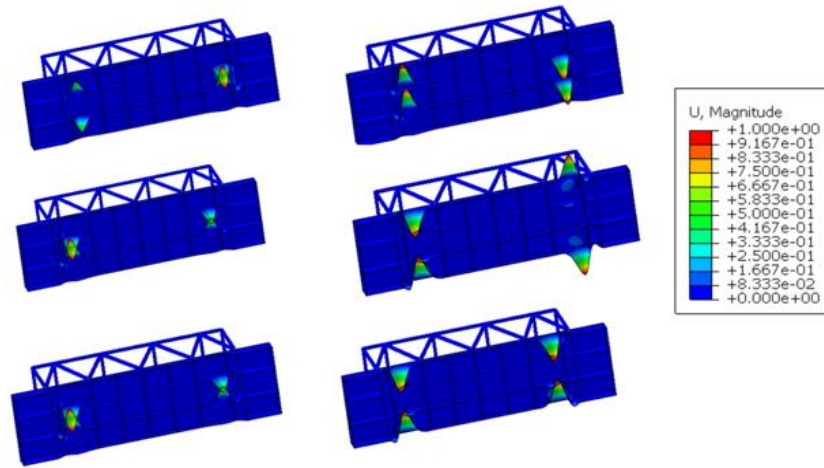

Fig 8. Flexural vibration pattern.

Flexing areas are always distributed at the bottom reinforcement plate position [9]. The first mode and the fourth mode are in in-plane flexion of the reinforcing plate in the reverse direction; the second mode is out-of-plane flexion of the reinforcing plate in the reverse direction; and the third mode and the fifth and sixth modes are in-plane flexion of the reinforcing plate in the same direction.

#### 4.4. Nonlinear buckling analysis

Since linear buckling analysis cannot take into account the initial defects and ignores the original deformation and stress state of the material, the model needs to be analysed for nonlinear buckling. Create a riks buckling analysis step, the introduction of the first eight orders of vibration defects, defect factor according to the national standard of steel structure, should be in the bridge length of 1%, that is, 90mm, this analysis in order to more accurately capture the point of buckling, the first eight orders of the defect factor are taken 5, that is, defects 5mm.

The load-displacement curve is shown in the figure below, the load is the uniform load of the bridge deck, and the displacement is taken as the vertical displacement at the middle of the bridge deck (Fig.9):

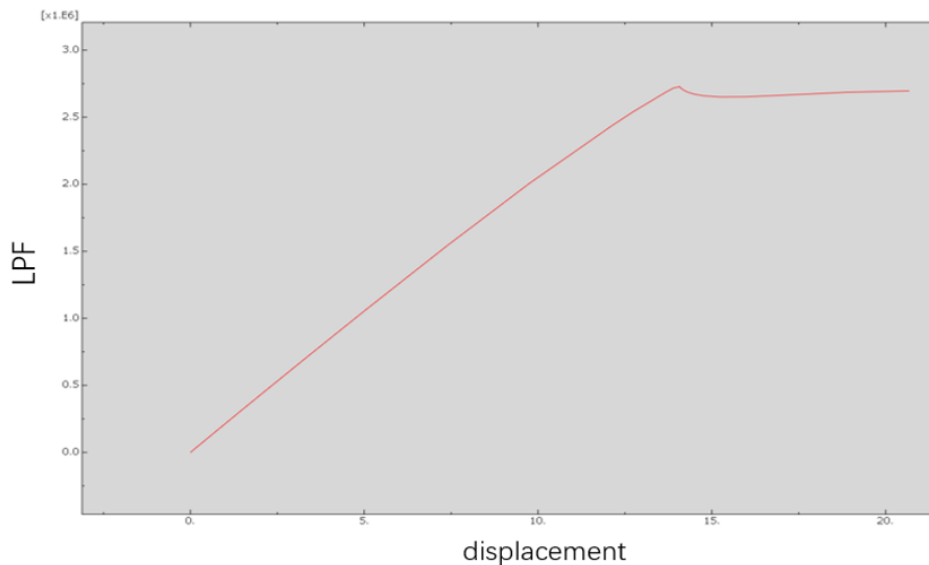

Figure 9. Load-displacement curve.

Since the linear buckling analysis is based on ideal material properties and assumes that the structure remains perfectly linear and elastic before buckling, the linear buckling load in this paper exists as an upper limit of the theory. The nonlinear buckling analysis takes into account the fact that the structure undergoes a large deformation during loading, which leads to a decrease in stiffness, thus reducing the buckling load. In addition, the material may enter a plastic phase, further reducing the structural load carrying capacity. In this paper, linear buckling loads are compared with nonlinear buckling loads to ensure experimental accuracy.

The buckling point load is  $2.72772e6\text{N}$ , which is less than the first order buckling load of linear buckling,  $4.47124e6\text{N}$ . The pedestrian load,  $32000\text{N}$ , taken statically as per the previous, is much less than the non-linear buckling load, and hence the bridge is designed to be safe.

## 5. Discussion

In this study, abaqus software is used as the basis of the research because steel joist structures may undergo large deformations under high loads, and the use of Abaqus is able to accurately take into account geometric nonlinear effects and thus simulate the buckling behaviour of the structure more realistically. In addition, Abaqus offers a wide range of buckling analysis methods to suit different analysis needs.

**Linear Buckling Analysis:** Used to quickly calculate the critical buckling loads and buckling modes of a structure.

Ideal for preliminary assessment of the stability of flyovers.

**Non-linear Buckling Analysis:** Takes into account geometrical and material non-linearities and enables more accurate prediction of the actual buckling behaviour.

The effect of initial defects on buckling stability can be modelled.

However, there are still limitations in this study, only pedestrian loads are considered in this study in terms of applied loads and dynamic loads such as earthquakes are ignored, and complex boundary conditions (e.g. articulated, fixed bearings) are not imposed, so the model set up in this study is an idealised model and deviates from the actual situation. In the future, the stability of steel truss structures should be comprehensively evaluated by considering various factors and simulating various combinations of working conditions in this kind of research.

## 6. Conclusion

This paper takes an indoor steel truss footbridge with a total length of 9m and a width of 2.5m as an example and analyses its stability under a pedestrian load of  $32000\text{N}$ . Through a series of methods, such as static analysis, buckling analysis, etc., we observe and study the parts of the model which are prone to instability, and calculate the buckling point load and the maximum instability force. Finally, the following main conclusions and recommendations are drawn from the calculation results.

(1) The maximum stress of the structure is  $4.987\text{Mpa}$ , which is much smaller than the yield strength of  $235\text{Mpa}$ , and the overall strength of the structure meets the standard. The size of the buckling point load is  $2.72772e6\text{N}$ , which is smaller than the maximum instability force of  $4.47124e6\text{N}$ , and the pedestrian load applied at the same time does not exceed the maximum instability force. Overall stability of the main steel truss satisfy the code requirements and have a high degree of richness.

(2) The flexural modes indicate that the model is susceptible to instability in the upper part of the top chord and web as well as in the area of the bottom reinforcement plate. The main buckling mode in the region of the bottom reinforcement plate is reverse in-plane buckling.

(3) The displacement at the centre of the model span is the largest, reaching  $0.2026\text{m}$ , but it is still less than the design maximum, and it is recommended that the appropriate footbridge should be strengthened with the stiffness at the centre of the span.

(4) Some experiments are needed in future work to verify the conclusions drawn from this study.

## Reference

- [1] Haifang He. Stability Analysis of “321” Prefabricated Highway Steel Truss Bridge[J]. Buildings 2024, 14(6), 1626
- [2] Xudong Wang. A Study of the Factors Influencing the Construction Risk of Steel Truss Bridges Based on the Improved DEMATEL–ISM[J]. Buildings 2023, 13(12), 3041
- [3] Long Piao. Welding Residual Stress Elimination Technique in the Top Chord of Main Truss of Steel Truss Bridge[J]. Buildings 2023, 13(5), 1267
- [4] Hidayat. Bridge deflection estimates from the measured rotation value of a steel truss bridge[J]. AIP Conference Proceedings, 2024, Vol.3026 (1)
- [5] Zhixiang Zou&Pengchao Yue. Research on key issues of truss footbridge design[J]. Chinese Science and Technology Journal Database (Full Text Edition) Engineering Technology, 2024, Issue 2: 0096-0099.
- [6] GB 50017-2017, Steel Structure Design Criteria[s].
- [7] Feng Mu. Load test detection and analysis of steel truss footbridge[A]. Jiangxi Building Materials, 2023(03):104-106
- [8] Yuan Yao& Liang Chen& Zhixing Chen & Yu Peng. Analytical study on buckling of steel truss[A]. Construction Technology, 2024 Vol. 55 No. 15: 1796-1800
- [9] Yurong Gui & Cheng Xiong& Jing Li& Yulong Chen& Qingxue Liang. Computational analysis of a steel truss footbridge[A]. Sichuan Construction, Vol. 44, No. 2: 142-144